

Y8 Maths Knowledge Organiser Topic 7: Area and Perimeter 2

<p>What must I be able to do?</p> <p>You may need to revise the following:</p> <ul style="list-style-type: none"> • Year 7 Topic 14: Area and Perimeter 1 <p>New content:</p> <ul style="list-style-type: none"> □ Convert between mm^2, cm^2 and m^2 □ Find the areas of trapezia <ul style="list-style-type: none"> ➤ Sparx M705 □ Find the areas and perimeters of composite shapes including rectangles, squares, triangles, parallelograms and trapezia. <ul style="list-style-type: none"> ➤ Sparx M996, M303 	<p>Key vocabulary</p> <table border="1" style="width: 100%;"> <tr> <td style="width: 50%;">Trapezium</td> <td>A quadrilateral with only <u>one</u> pair of parallel sides. The plural of trapezium is trapezia.</td> </tr> <tr> <td>Composite shapes</td> <td>Shapes created by combining other shapes</td> </tr> </table>	Trapezium	A quadrilateral with only <u>one</u> pair of parallel sides. The plural of trapezium is trapezia.	Composite shapes	Shapes created by combining other shapes
Trapezium	A quadrilateral with only <u>one</u> pair of parallel sides. The plural of trapezium is trapezia.				
Composite shapes	Shapes created by combining other shapes				

Area of a trapezium

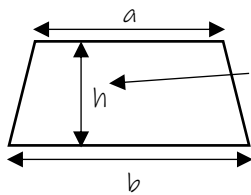

Height must be perpendicular to the parallel sides.

$$\text{Area} = \frac{1}{2}(a + b)h$$

$\frac{1}{2}(a + b)$ finds the average length of the parallel sides. This essentially turns the formula into the same as for the area of a parallelogram!

Converting units of area

When converting units of area, you need to do the standard length conversion rule twice, once for each dimension.

$$1\text{m}^2 = 1\text{m} \times 1\text{m} = 100\text{cm} \times 100\text{cm} = 10,000\text{cm}^2$$

$$1\text{cm}^2 = 1\text{cm} \times 1\text{cm} = 10\text{mm} \times 10\text{mm} = 100\text{mm}^2$$

$$\text{Therefore } 1\text{m}^2 = 1,000,000\text{mm}^2$$

Area of composite shapes

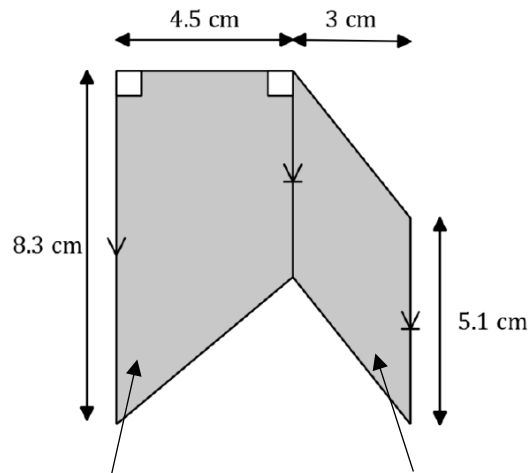

Area of the trapezium is:

$$\frac{1}{2} \times (8.3 + 5.1) \times 4.5 = 30.15\text{cm}^2$$

Area of the parallelogram is:

$$5.1 \times 3 = 15.3\text{cm}^2$$

So the total area of the composite shape is:

$$30.15 + 15.3 = 45.45\text{cm}^2$$

Y8 Maths Knowledge Organiser Topic 8: Negative numbers 2

<p>What must I be able to do?</p> <p>You may need to revise the following:</p> <ul style="list-style-type: none"> • Year 7 Topic 6: Negative numbers 1 <p>New content:</p> <ul style="list-style-type: none"> □ Use correctly the symbols $<$, $>$, \geq, \leq, and the associated language to order a set of decimals and integers including negatives 	<p>Key vocabulary</p> <table border="1" style="width: 100%;"> <tr> <td style="width: 50%;">Greater than</td> <td>The symbol $>$ represents greater than. It means <u>bigger</u>.</td> </tr> <tr> <td>Less than</td> <td>The symbol $<$ represents less than. It means <u>smaller</u>.</td> </tr> <tr> <td>Greater than or equal</td> <td>The symbol \geq represents greater than or equal to. It means <u>bigger</u> but also includes the possibility of it being <u>equal</u>.</td> </tr> <tr> <td>Less than or equal</td> <td>The symbol \leq represents less than or equal to. It means <u>smaller</u> but also includes the possibility of it being <u>equal</u>.</td> </tr> </table>	Greater than	The symbol $>$ represents greater than. It means <u>bigger</u> .	Less than	The symbol $<$ represents less than. It means <u>smaller</u> .	Greater than or equal	The symbol \geq represents greater than or equal to. It means <u>bigger</u> but also includes the possibility of it being <u>equal</u> .	Less than or equal	The symbol \leq represents less than or equal to. It means <u>smaller</u> but also includes the possibility of it being <u>equal</u> .
Greater than	The symbol $>$ represents greater than. It means <u>bigger</u> .								
Less than	The symbol $<$ represents less than. It means <u>smaller</u> .								
Greater than or equal	The symbol \geq represents greater than or equal to. It means <u>bigger</u> but also includes the possibility of it being <u>equal</u> .								
Less than or equal	The symbol \leq represents less than or equal to. It means <u>smaller</u> but also includes the possibility of it being <u>equal</u> .								

Using inequalities with negatives

e.g. $x < 4$ Write down 2 possible values for x if:

a) $y = 1$

$x = 0$ or $x = 0.5$

b) $y = 0$

$x = -1$ or $x = -20$

e.g. put a correct symbol in each circle

a) -4 > -5

b) $-\frac{1}{2}$ < $-\frac{1}{4}$